

24 A

Diamond Metal Meshes

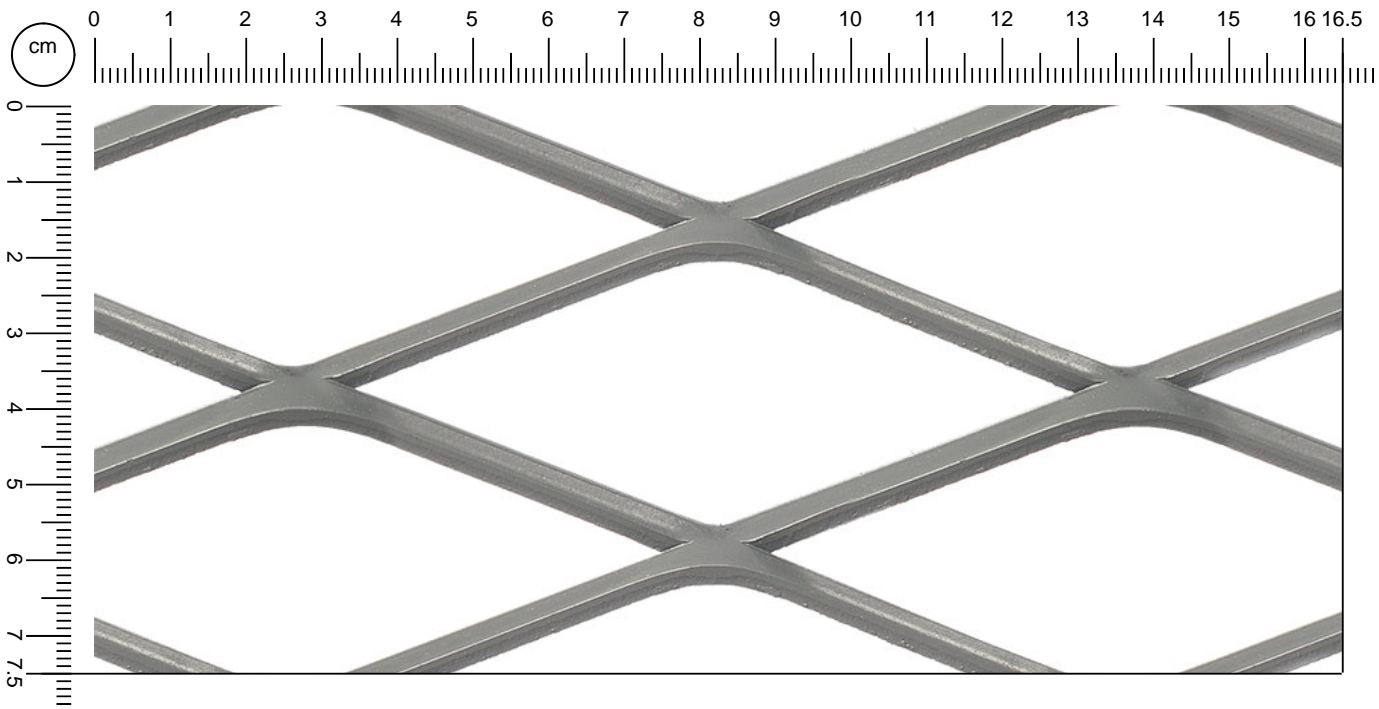

Riferimenti

Nome	= Geom DL x DCn (DCr) - av x sp
Geom	= Esagonale, Romboidale, Quadra
DL	= Diagonale Lunga
DCn	= Diagonale Corta nominale (riferimento interno)
DCr	= Diagonale Corta reale
av	= Avanzamento
sp	= Spessore
Larg - DL	= Larghezza in direzione DL
Lung - DC	= Lunghezza in direzione DC (direzione di stiratura)

Product
R 110 x 4

Material

Carbon st

Dimensioni



Dimensione maglia



Facciata a vista

