

# 73

## Diamond Metal Meshes

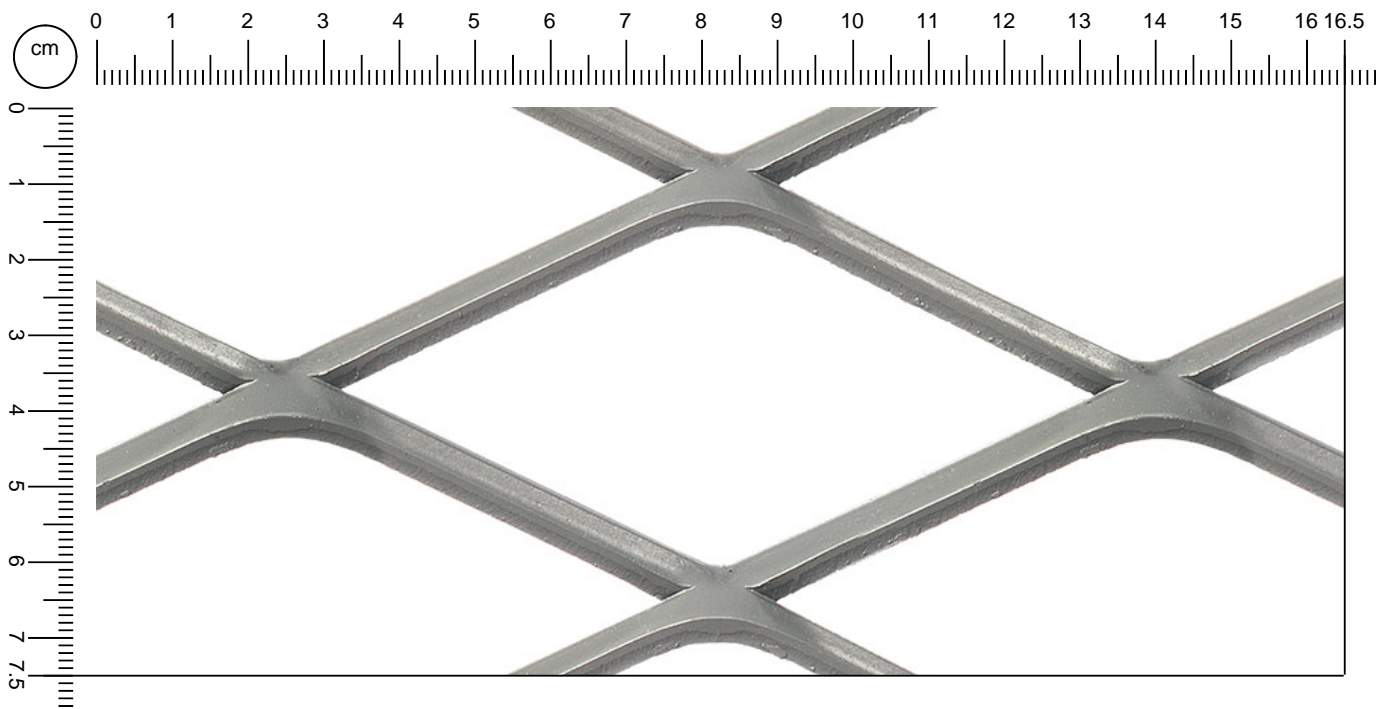

**Product data:**  
R 115 x 55 (63) - 3 x t

Material	Name	sp mm	Weight kg/m <sup>2</sup>	Sheet On demand
Carbon steel	R 115 x 55 (63) - 3 x 3	3.0	2.5	✔